

Bending machines

CNC BASH 5
CNC BASH 12
CNC BASH 12+



Benefits of cooperation

- ✓ Modularity and Customization
- ✓ Short cycle time, up to 50% faster than competition
- ✓ Energy efficiency
- ✓ Full process automation
- ✓ Long life cycle & low service costs
- ✓ Easy maintenance

CNC BASH

Easy access
Scan to see more
product documents



Technical information overview

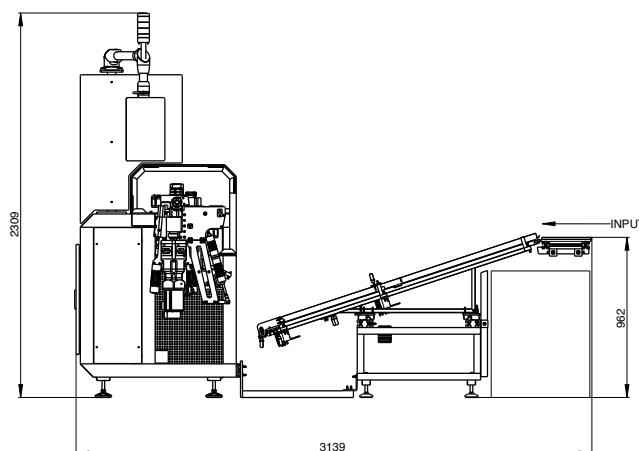
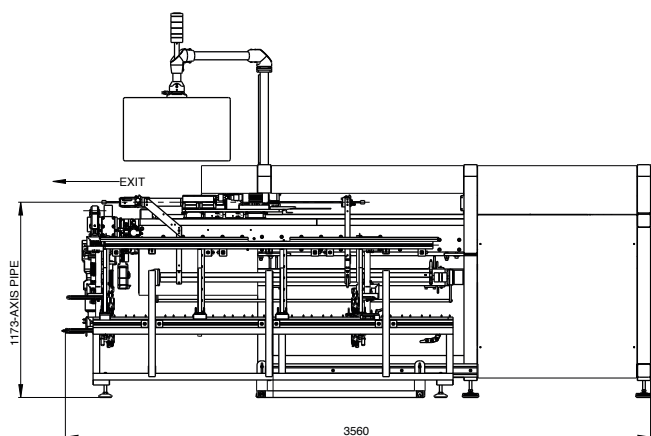

| | CNC BASH 5 | CNC BASH 12 | CNC BASH 12+ |
|---------------------------------------|-------------------------------------|-------------------------------------|-------------------------------------|
| Number of tool levels | 3 | 3 | 3 |
| Bending direction | LEFT-RIGHT automatic changing head | LEFT-RIGHT automatic changing head | LEFT-RIGHT automatic changing head |
| Bending radius | 12 - 20 mm (another size as option) | 12 - 40 mm (another size as option) | 12 - 40 mm (another size as option) |
| Tact-time | < 2 s/bend | < 2 s/bend | < 2 s/bend |
| Material | Steel, Stainless steel, Aluminium | Steel, Stainless steel, Aluminium | Steel, Stainless steel, Aluminium |
| Max pipe diameter (metal core) | 6,5 mm | 12 mm, 16 mm Al | 14 mm, 19 mm Al |
| Pipe length | 150-2000 mm | 150-2000 mm | 150-2000 mm |